

承认书

SPECIFICATION FOR APPROVAL

客户 (CUSTOMER): _____

客户料号 (CUST P/N): _____

产品物料编号: (PART. NO): 137018000769

奥迪威产品名称 (DESCRIPTION): PL0544-016

奥迪威产品型号 (P/N): AW2E34. 55G-32S1L16Z

规格书编号 (SPECIFICATION. NO): K2-WSP-PL-00502

规格书版本 (VERSION): A1

■ 规格书状态 (Specs Type):

■ 样件 (Sample Specs)

□ 量产 (Standard Specs)

样件规格书 (Sample Specs):

适用于产品的小批量试制. (Apply to trial order.)

量产规格书 (Standard Specs):

适用于产品的批量生产. (Apply to mass production.)

客户承认 CUSTOMER APPROVAL	签名 SIGNATURE.	承认章 COMPANY CHOP.

编制 DWN.	审核 CHK.	批准 APPD.

■ 产品规格书仅供参考, 在产品量产之前, 需要确认最新版本的量产规格书, 并得到客户的签名承认. (Specifications are for reference only, and it is required to be approved by customers before mass production.)

注: 承认书一式两份, 请返回一份. (Note: Specs are in duplicate, please send one copy back.)



焊线蜂鸣片产品规格书

(PIEZO ELEMENT SPECIFICATIONS)

■ 产品型号(MODEL): AW2E34.55G-32S1L16Z

■ 电性能参数(SPECIFICATIONS):

NO	Items 项目	Specification 规格	Note 备注
1	Resonant frequency 谐振频率	3.2±0.3KHz	PV70A 带线 (with wires)
2	Main electrostatic capacity 电容量	25000±30% pF	Digital electric bridge At 1KHz/1V 数字电桥 1KHz/1V
3	Resonant impedance 谐振阻抗	600 MAX.	PV70A WITH WIRES 带线
4	Metal plate material 金属基片材质	SUS304	----
5	Metal plate diameter 金属基片直径	Φ 34.55±0.10mm	Vernier caliper 游标卡尺
6	Metal plate thickness 金属基片厚度	0.30±0.02mm	Micrometer 千分尺
7	Ceramic diameter 陶瓷片直径	Φ 25.0±0.30mm	Vernier caliper 游标卡尺
8	Total height 总厚度	0.54 ^{+0.08} _{-0.05} mm	Micrometer 千分尺
9	Insulation resistance 绝缘阻抗	100MΩ MIN	Insulation resistance tester At 50V 绝缘抵抗测试仪 50V
10	Operating temperature range 工作温度	-20°C to +70°C	----
11	Storage temperature range 储存温度	-30°C to +80°C	----
12	Lead wires 线规格	UL1571AWG28#RED/BLA CK/WHITE	----

■ 外观尺寸 (APPEARANCE AND DIMENSIONS, Unit 单位: mm):

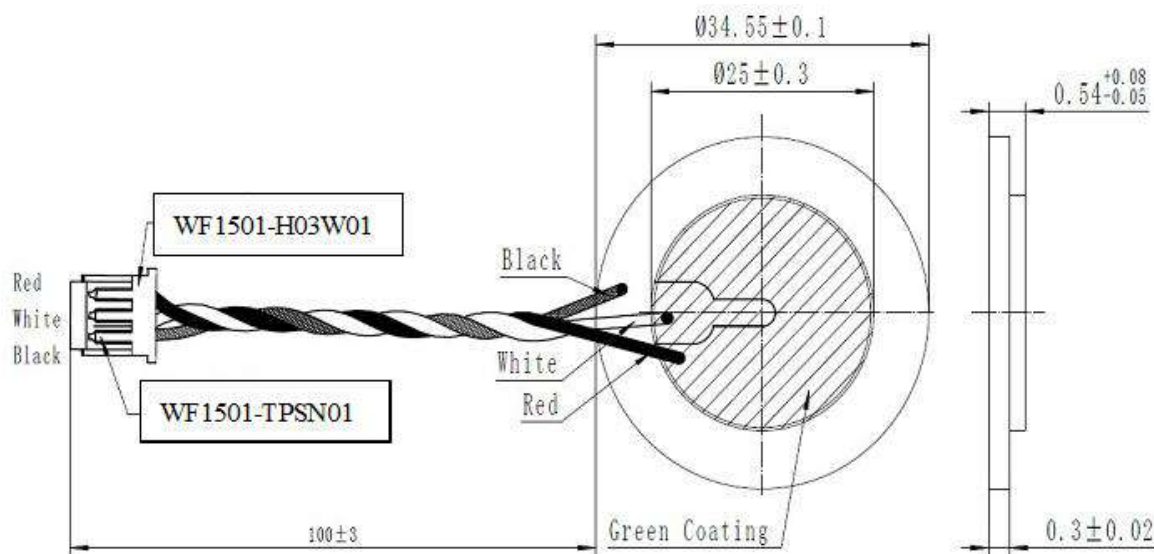

Remark: The Pb in ceramic is exempt, other ingredients are all ROHS compliant.

注: 压电陶瓷豁免含铅量, 其余物料符合 RoHS 环保要求.

■ 典型频率响应曲线 (TYPICAL FREQUENCY RESPONSE CURVE)

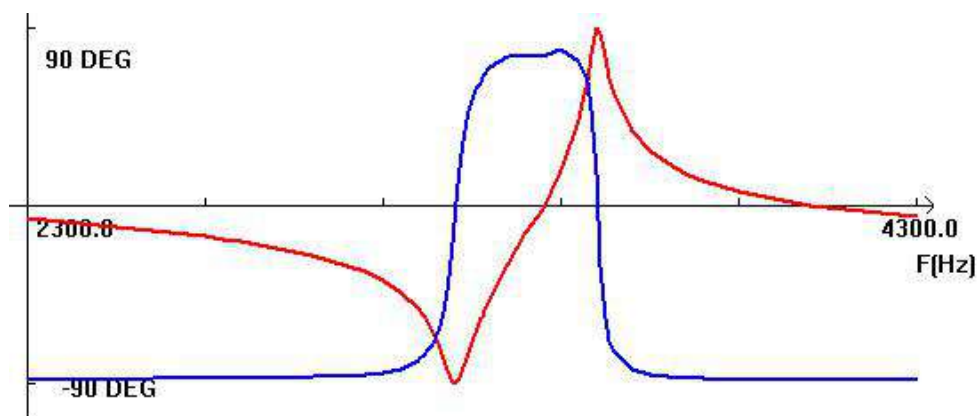

■ 产品测试方法 (MEASURING PROCEDURE)

The node held with a measuring terminal, the resonant frequency and resonant impedance are measured in the constant-voltage circuit.

产品连接到测试终端, 在持续电压的线路中测试谐振频率和共振阻抗。

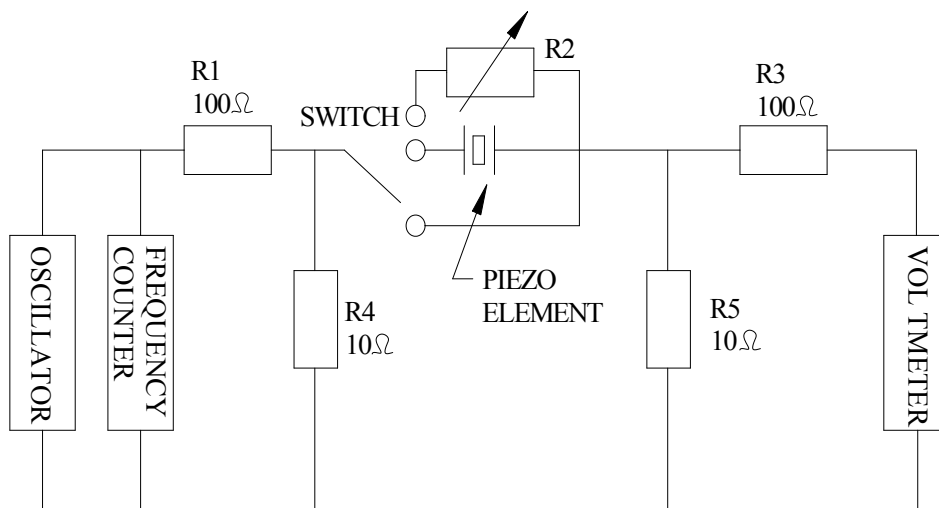

■ 修订记录(revision history)

文件修订记录 File revision history			
修订时间 Revision time	修订版本 Version of revision	内部 ECR 编号 The number of ECR	修订内容 Contents of revision
2018/1/12	A1	/	新建规格书

制作/日期 Accomplished by / Date		确认/日期 Approved by / Date	
---------------------------------	--	-----------------------------	--

